

# MANTIS 270A



**XB 270A**

## Among the lightest and most portable of large Band Saws! Does just about everything you need to do at site!

We've brought you safety, we've brought you ease of use - now we bring you a brand new machine in the Mantis Series. Hydraulic cylinder inside base unit allows variable adjustment of the frame lowering speed.

### Features (Letters A to F refer to diagram below)

- Handles up to 10" pipe
- 4 wheels built in for great portability - **A**
- Lightest in its class
- Oil-free cutting
- Hydraulic damper and spring allows smooth adjustment of cutting speed - **B**
- Cuts at angles from 0° to 45°
- Lets you replace the blade from the front (same as Mantis 180W) - **C**
- Built-in brush for plastic waste (same as Mantis 180W) - **D**
- Reset switch for when overload protection kicks in - **E**
- Clamp to keep pipe in place - **F**



**Flat Vice Only**

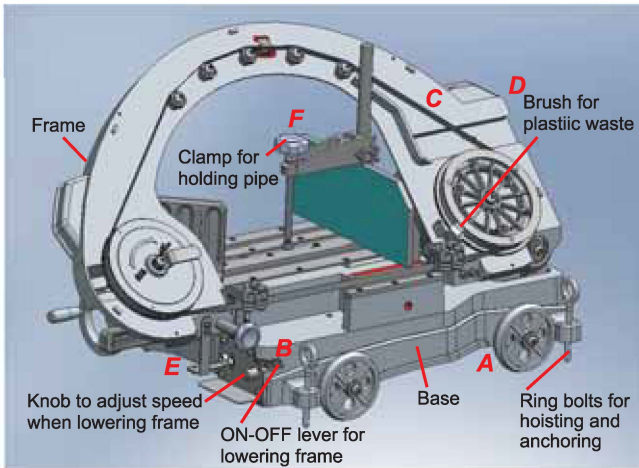

### Blades

Code no.	475270
Material	HSS (Bimetal)
No. of teeth (teeth / inch)	14
No. of blades included	5

### Specifications and Equipment

- Motor** : Single phase 220V (50/60Hz), Split-phase induction motor 250W, with overload protection
- Pulley speed** : 70 min<sup>-1</sup>(50Hz), 84 min<sup>-1</sup> (60Hz)
- Overall dimensions (mm)** : L 990 x W510 x H600
- Weight (kg)** : 80kg
- Standard accessories** : 14-tooth HSS blade (x1) (Code No. 475270), Hex key wrench 8mm, Spanner for adjustment of vice angle, Wrench (19mm)
- Optional accessories** : 14-tooth HSS blade (Code No. 475270)  
Cutting-length guide (Code No. 475196)



*Cutting-length guide*

Code no.	Model	Vice	Motor	Dimensions LxWxH (mm)	Cutting capacity (mm)				Weight (Kg)
					90°		45°		
					Round Pipe	Square pipe	Round Pipe	Square pipe	
4751C1	REX Mantis270A	Flat vice	Single phase 220V (50/60Hz), Split-phase induction motor 250W, with overload protection	L990xW510xH600	270 (10")	250	170 (6")	150	80

## REX INDUSTRIES CO.,LTD.

Overseas Sales Dept. & Factory :  
1-9-3, Hishiyahigashi, Higashi Osaka 578-0948, Japan  
Tel.: +81 - (0)72 - 961 - 9820 Fax.: +81 - (0)72 - 961 - 9878  
ISO9001; 2000 : JQA-2387 / ISO14001 : JQA-EM2926



- Be sure to read the operating manual before use.  
- Changes in specifications, colour, etc. may be made without prior notification.